

# Spring plungers with hex socket and POM thrust pin, steel, with thread lock

Item description/product images

KIPPlack

## Description

### Material:

Sleeve steel grade 5.8.

Thrust pin POM.

Spring grade D spring steel wire.

Thread lock nylon.

### Version:

Black oxidised.

### Drawing reference:

L2 = ca. two full threads

1) grub screw glued-in



## Drawings

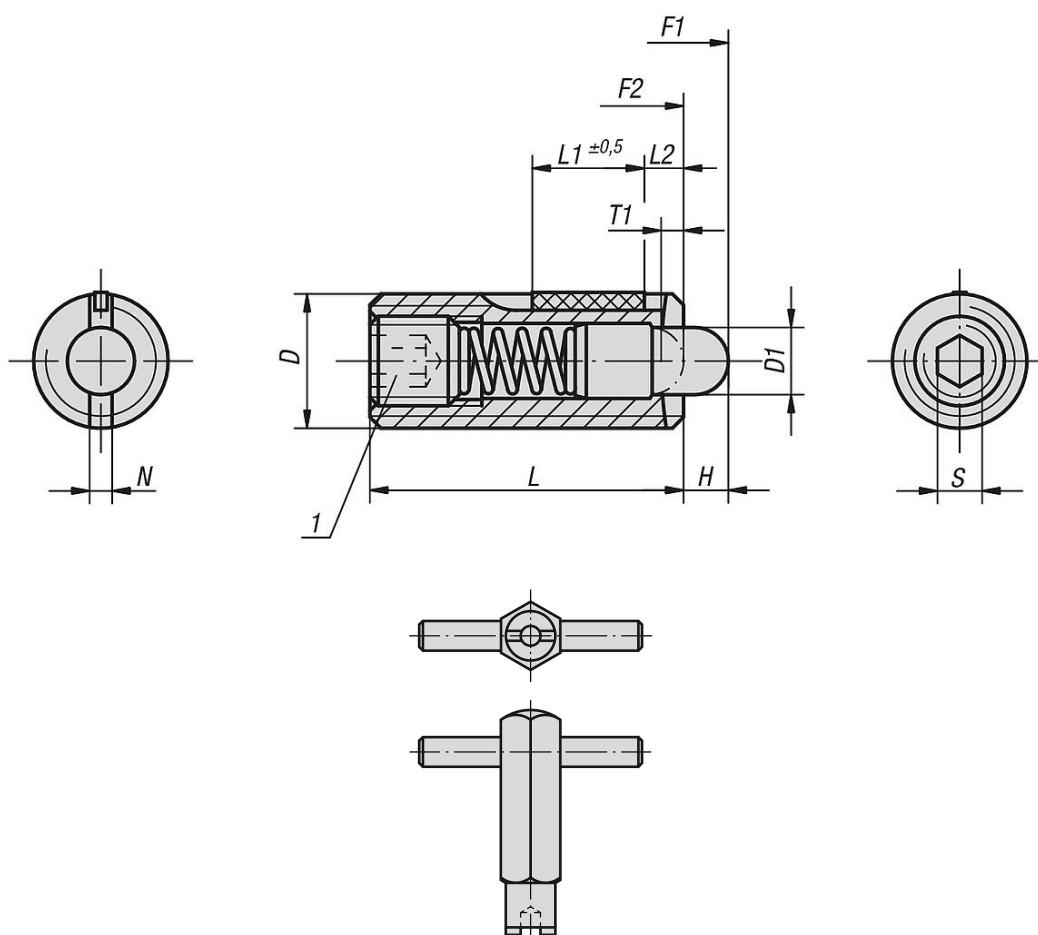

## Overview of items

Spring plungers with hex socket and POM thrust pin, steel, with thread lock

## Spring plungers with hex socket and POM thrust pin, steel, with thread lock

### Overview of items

Order No.	D	D1	H	L	L1	T1	N	S	Spring force initial pressure F1 approx. N	Spring force final pressure F2 approx. N	Tightening torque approx. Nm	Loosening torque approx. Nm	Order No. Assembly key
K0328.05	M5	2,4	2,3	18	7	0,8	0,8	1,5	6	20	0,12	0,08	K0317.905
K0328.06	M6	2,7	2,5	20	7	1	1	2	7	20	0,45	0,22	K0317.906
K0328.08	M8	3,5	3	22	8	1,4	1,2	2,5	9	35	1,05	0,37	K0317.908
K0328.10	M10	4	3	22	9	1,4	1,6	3	9	35	1,3	0,6	K0317.910
K0328.12	M12	6	4	28	10	2	2	4	12	55	2	1,3	K0317.912
K0328.16	M16	7,5	5	32	14	2,5	2,5	5	45	100	3,9	3	K0317.916
K0328.105	M5	2,4	2,3	18	7	0,8	0,8	1,5	3	10	0,12	0,08	K0317.905
K0328.106	M6	2,7	2,5	20	7	1	1	2	3	9	0,45	0,22	K0317.906
K0328.108	M8	3,5	3	22	8	1,4	1,2	2,5	4	16	1,05	0,37	K0317.908
K0328.110	M10	4	3	22	9	1,4	1,6	3	4	16	1,3	0,6	K0317.910
K0328.112	M12	6	4	28	10	2	2	4	5	27	2	1,3	K0317.912
K0328.116	M16	7,5	5	32	14	2,5	2,5	5	20	45	3,9	3	K0317.916