

Spring plungers with hexagon socket and thrust pin, long version

Item description/product images



Description

Material:

Sleeve steel grade 5.8.
Thrust pin steel.
Spring steel wire grade D.

Version:

Black oxidised.
Thrust pin hardened.

Note:

These spring plungers are chiefly used as ejectors and spring stops in machine construction.

Drawing reference:

1) grub screw glued in

bending

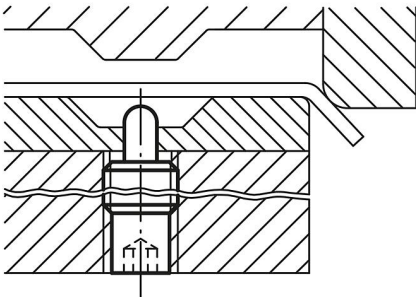

ready to eject

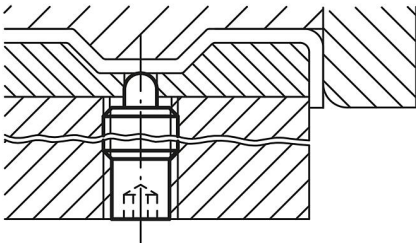

Spring plungers with hexagon socket and thrust pin, long version

Drawings

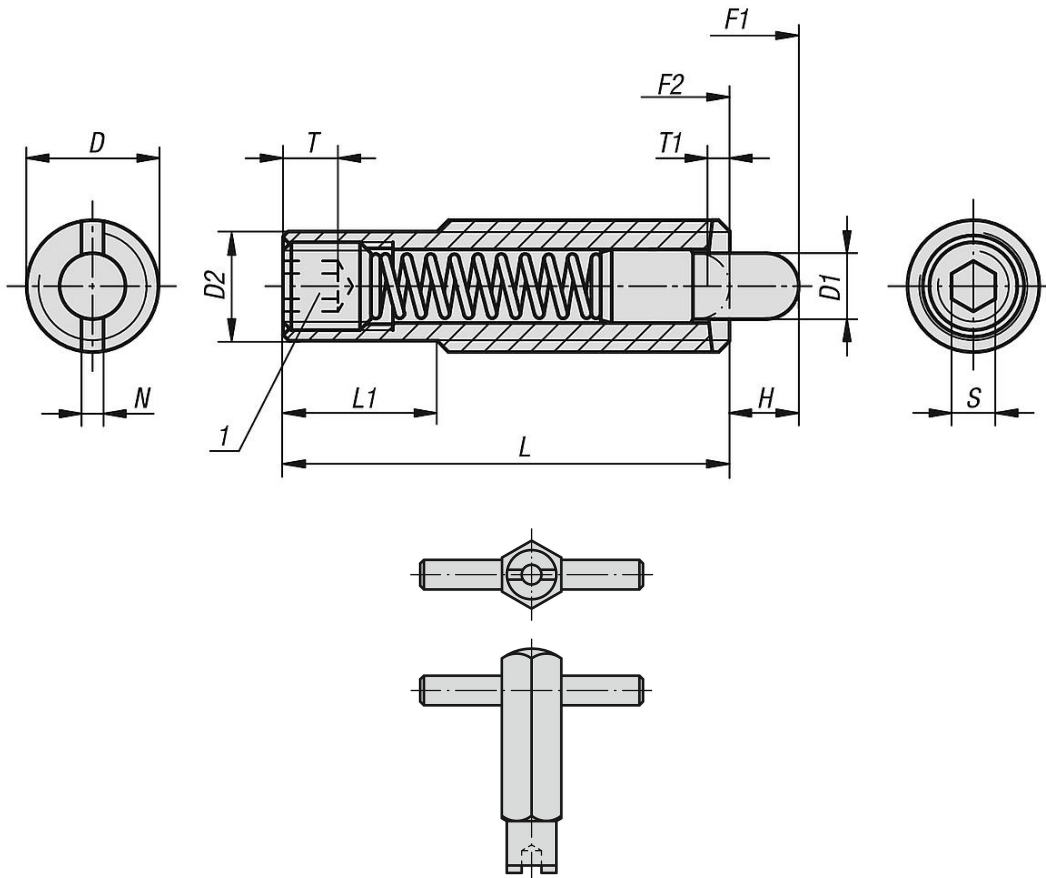

Overview of items

Spring thrust pin with hexagon socket and thrust pin, long version

Order No.	D	D1	D2	L	L1	H	T	T1	N	S	Spring force initial pressure F1 approx. N	Spring force final pressure F2 approx. N	Order No. Assembly key
K0657.608X30	M8	3,5	6,2	30	10	6	-	1,4	1,2	2,5	8	20	K0317.908
K0657.608X40	M8	3,5	6,2	40	20	8	-	1,4	1,2	2,5	10	28	K0317.908
K0657.608X50	M8	3,5	6,2	50	30	10	-	1,4	1,2	2,5	12	38	K0317.908
K0657.608X60	M8	3,5	6,2	60	40	15	-	1,4	1,2	2,5	15	45	K0317.908
K0657.610X40	M10	4	8	40	10	8	-	1,4	1,6	3	12	30	K0317.910
K0657.610X50	M10	4	8	50	20	10	-	1,4	1,6	3	16	46	K0317.910
K0657.610X60	M10	4	8	60	30	15	-	1,4	1,6	3	20	55	K0317.910
K0657.610X80	M10	4	8	80	50	20	-	1,4	1,6	3	25	65	K0317.910
K0657.612X50	M12	6	9,6	50	20	10	-	2	2	4	20	50	K0317.912
K0657.612X60	M12	6	9,6	60	30	15	-	2	2	4	25	76	K0317.912
K0657.612X80	M12	6	9,6	80	50	20	-	2	2	4	35	102	K0317.912
K0657.612X100	M12	6	9,6	100	70	25	-	2	2	4	40	102	K0317.912
K0657.616X60	M16	7,5	13,4	60	30	12	-	2,5	2,5	5	30	64	K0317.916
K0657.616X80	M16	7,5	13,4	80	50	20	-	2,5	2,5	5	30	110	K0317.916
K0657.616X100	M16	7,5	13,4	100	70	30	-	2,5	2,5	5	30	120	K0317.916
K0657.616X120	M16	7,5	13,4	120	90	40	-	2,5	2,5	5	20	130	K0317.916

