

Indexing plungers, steel or stainless steel without collar, with threaded pin

Item description/product images



Description

Material:

Steel version

Indexing pin hardened:
grade 5.8.

Stainless steel version

Indexing pin hardened:
Threaded sleeve 1.4305.
Indexing pin 1.4034.

Indexing pin not hardened:

Threaded sleeve 1.4305.
Indexing pin 1.4305.

Version:

Steel version:

Indexing pin hardened, ground, black oxidised.

Stainless steel version:

Indexing pin hardened, ground and bright.

Indexing pin not hardened, ground and bright.

Note:

Indexing plungers are used to prevent any change in locking position due to lateral forces. A new locking position can only be set after the pin has been disengaged. Special grips can be fitted on the projecting threaded pin. This pin is also suitable for automatic actuation by e.g. program controlled pneumatic cylinder or by remote control using bowden cables.

A washer is available to aid screwing in the indexing plungers. The washer is placed on the threaded sleeve so that the carrier pins engage in the slot.

On request:

Special versions.

Accessory:

Spacer rings K0665

Indexing plungers, steel or stainless steel without collar, with threaded pin

Drawings

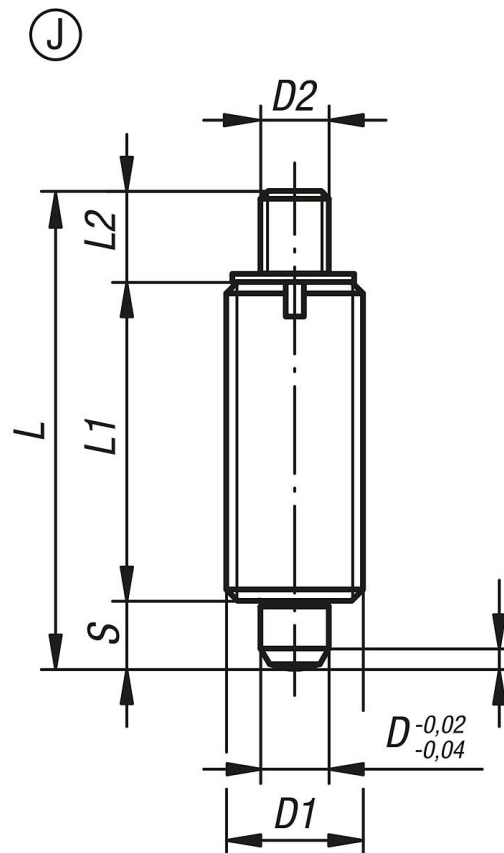

Overview of items

Order No.	Form	Main material	Surface finish body	D	D1	D2	L	L1	L2	Travel S	Fx30°	Spring force initial pressure F1 approx. N	Spring force final pressure F2 approx. N	Order No. screw-in washer
K0345.1903	J	steel	hardened	3	M6x0,75	M2	24	17	3,5	3,5	0,8	4,5	10	K0344.99
K0345.1004	J	steel	hardened	4	M8x1	M3	32	21	7	4	1	6	12	K0344.90
K0345.1105	J	steel	hardened	5	M10x1	M4	37	24	8	5	1,3	5	12	K0344.91
K0345.1206	J	steel	hardened	6	M12x1,5	M6	42	28	8	6	1,8	6	14	K0344.92
K0345.1308	J	steel	hardened	8	M16x1,5	M8	56	36	12	8	2,3	15	35	K0344.93
K0345.1410	J	steel	hardened	10	M20x1,5	M8	62	40	12	10	2,8	15	34	K0344.94
K0345.1412	J	steel	hardened	12	M20x1,5	M8	66	42	12	12	2,8	15	39	K0344.94
K0345.1516	J	steel	hardened	16	M24x2	M10	80	50	14	16	3,2	20	46	K0344.95
K0345.01903	J	stainless steel	hardened	3	M6x0,75	M2	24	17	3,5	3,5	0,8	4,5	10	K0344.99
K0345.01004	J	stainless steel	hardened	4	M8x1	M3	32	21	7	4	1	6	12	K0344.90
K0345.01105	J	stainless steel	hardened	5	M10x1	M4	37	24	8	5	1,3	5	12	K0344.91
K0345.01206	J	stainless steel	hardened	6	M12x1,5	M6	42	28	8	6	1,8	6	14	K0344.92
K0345.01308	J	stainless steel	hardened	8	M16x1,5	M8	56	36	12	8	2,3	15	35	K0344.93
K0345.01410	J	stainless steel	hardened	10	M20x1,5	M8	62	40	12	10	2,8	15	34	K0344.94
K0345.01412	J	stainless steel	hardened	12	M20x1,5	M8	66	42	12	12	2,8	15	39	K0344.94
K0345.01516	J	stainless steel	hardened	16	M24x2	M10	80	50	14	16	3,2	20	46	K0344.95
K0345.11903	J	stainless steel	not hardened	3	M6x0,75	M2	24	17	3,5	3,5	0,8	4,5	10	K0344.99
K0345.11004	J	stainless steel	not hardened	4	M8x1	M3	32	21	7	4	1	6	12	K0344.90
K0345.11105	J	stainless steel	not hardened	5	M10x1	M4	37	24	8	5	1,3	5	12	K0344.91
K0345.11206	J	stainless steel	not hardened	6	M12x1,5	M6	42	28	8	6	1,8	6	14	K0344.92
K0345.11308	J	stainless steel	not hardened	8	M16x1,5	M8	56	36	12	8	2,3	15	35	K0344.93
K0345.11410	J	stainless steel	not hardened	10	M20x1,5	M8	62	40	12	10	2,8	15	34	K0344.94
K0345.11412	J	stainless steel	not hardened	12	M20x1,5	M8	66	42	12	12	2,8	15	39	K0344.94
K0345.11516	J	stainless steel	not hardened	16	M24x2	M10	80	50	14	16	3,2	20	46	K0344.95

Indexing plungers, steel or stainless steel without collar, with threaded pin

Overview of items
