

Filler necks

Item description/product images



Description

Material, version:

1. Sealing cap red Polyamide 66 thermoplastic.
2. Filler sieve black Polypropylene thermoplastic.
- 3 Flange electro zinc-plated steel.
4. Fastening screws electro zinc-plated steel.
- 5 Flange seal cork.
6. Chain brass.

Note:

Form A: the max. pressure while venting is 50 mbar (0.73 psi) with a max. air volume of 500 l/min. The air filter prevents dirt entering.

Form B: contains a plastic vent and aeration valve. The opening pressure while venting is 0.35 bar (± 0.05 bar). The opening pressure while aerating is 0.05 bar. This form is suitable for applications where the airflow needs to be controlled in both directions.

Drawings

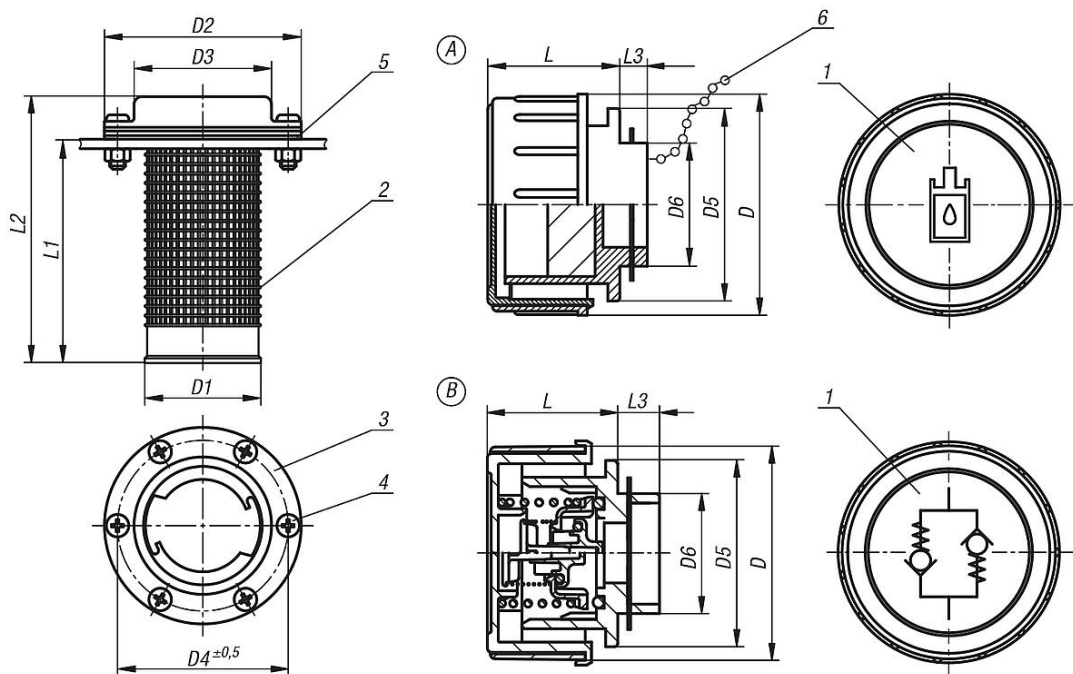

Overview of items

Filler necks

Overview of items

Order No.	Form	Version 2	D	D1	D2	D3	D4	D5	D6	L	L1	L2	L3
K1103.170	A	with filter	70	46	83	58	72	60	37	41	94	115	14
K1103.270	B	vent valve	70	46	83	58	72	60	37	41	94	115	14