

Floating clamp with separate workpiece clamp and interlock

Item description/product images



Description

Material:

Base body and jaws steel.
Housing aluminium.

Version:

Body nitrided, black oxidised and ground.
Jaws nitrided and black oxidised.
Housing blue anodised.

Note:

The floating clamp is used to clamp and support overhanging points on thin walled, sensitive and pliable components. It prevents vibrations and bending during machining.

Type of operation:

1. Push the floating clamp down.
2. Pivot the jaws in. The lower jaw contacts the workpiece with a light spring force.
3. Tighten the AF 18 hexagon nut with max. 15 Nm torque. The jaws clamp the workpiece, the clamp is still floating.
4. Tighten the AF 10 hexagon nut with max. 10 Nm torque. The clamping process is completed.
5. Reverse the process to release.

Assembly:

Form A:

Fasten the floating clamp to the fixture with the M12 screw.
Adjust the height stop and the swivel range using the blue sleeve and lock with the 3x2.5 mm grub screws. When setting the height leave generous clearance above.
For safe operation the M12 tapped hole must always be closed.
For specific clamping applications the standard jaws can be altered or replaced.

Form B:

Fasten the floating clamp with M6 fastening holes to a fixture.
Adjust the height stop and pivot range using the blue adjusting sleeve and clamp with grub screws (4x AF 2.5). When setting the height limit, allow ample play at the top.
For specific clamping situations, the standard jaw plates can be modified or replaced.

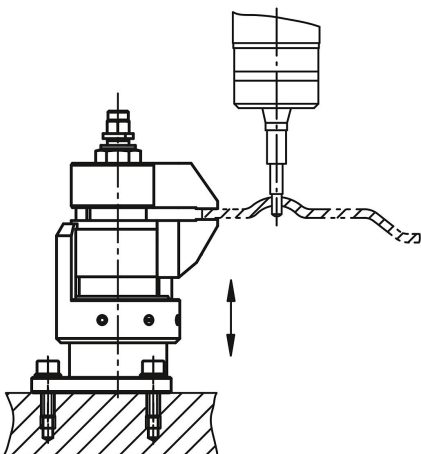
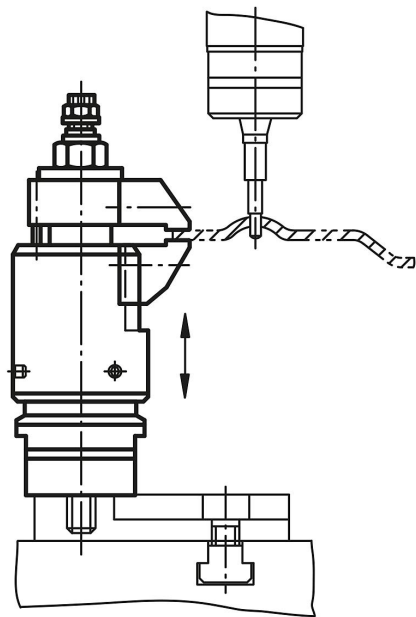

Floating clamp with separate workpiece clamp and interlock

Drawings

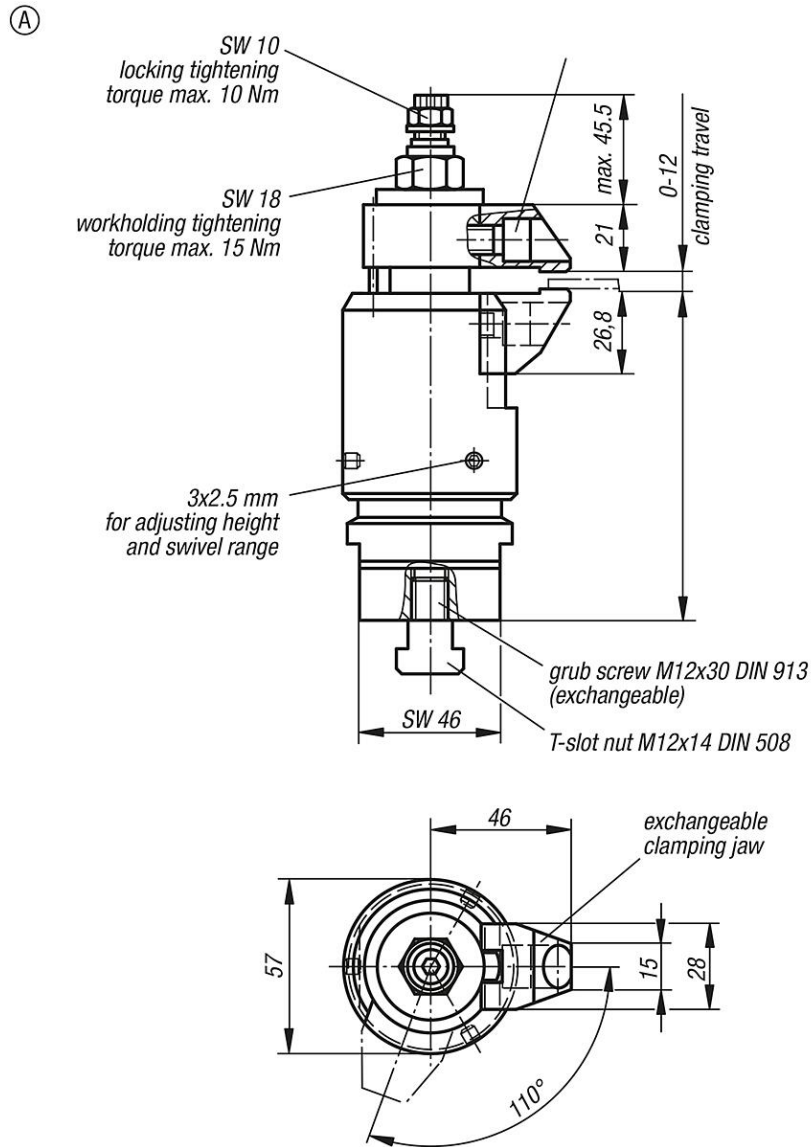

Floating clamp with separate workpiece clamp and interlock

Drawings

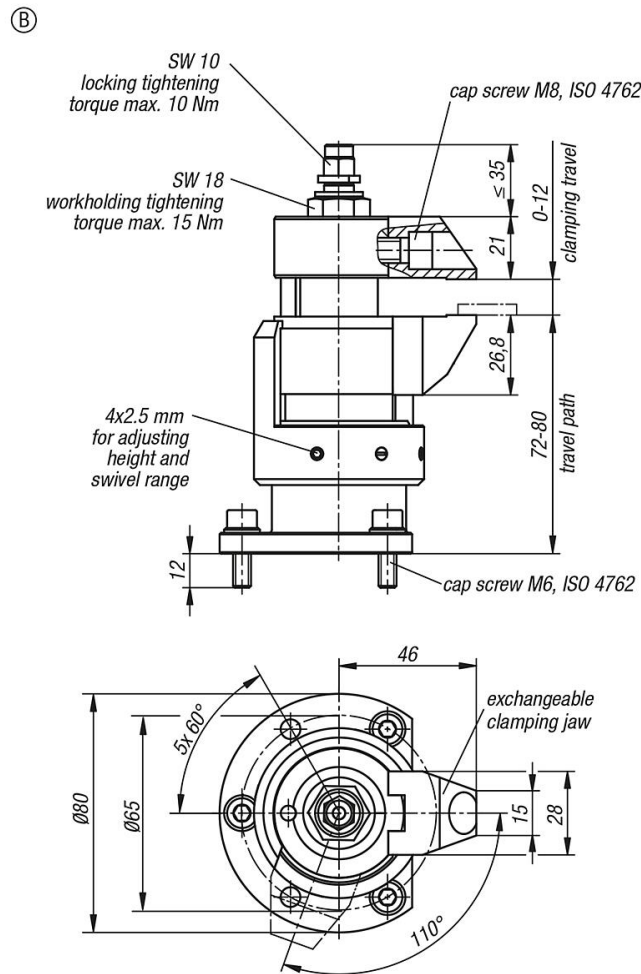

Overview of items

Floating clamp with separate workpiece clamp and interlock

Order No.	Form	Travel path	max. clamping travel	Load capacity N	Clamping force N
K1227.100812	A	10 mm	12	8000	8000
K1227.080812	B	8	12	8000	8000