

Interchangeable subplates, grey cast iron with grid holes

Item description/product images

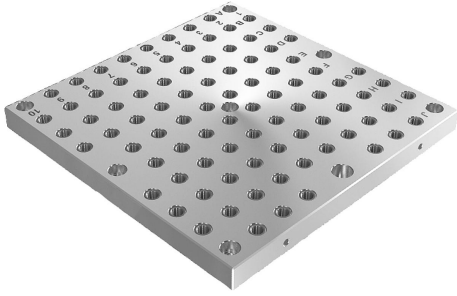

Description

Material:
GJL 300.

Version:
Mounting surfaces ground

Note:

Interchangeable subplates with grid holes are used double-sided, together with the tombstones. The interchangeable subplates are positioned and mounted on both sides of the tombstone. This means that clamping fixtures can be replaced efficiently.

The alphanumerically labelled grid holes mean that the clamping elements can be assigned in a defined manner in the event of repeat setups.

Please order protection plugs to plug unused grid holes separately.

Drawing reference:

- 1) grid hole
- 2) hole for DIN 912 cap screw, M16

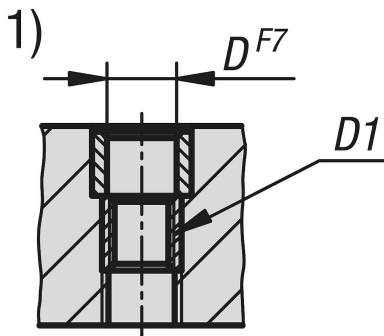

Drawings

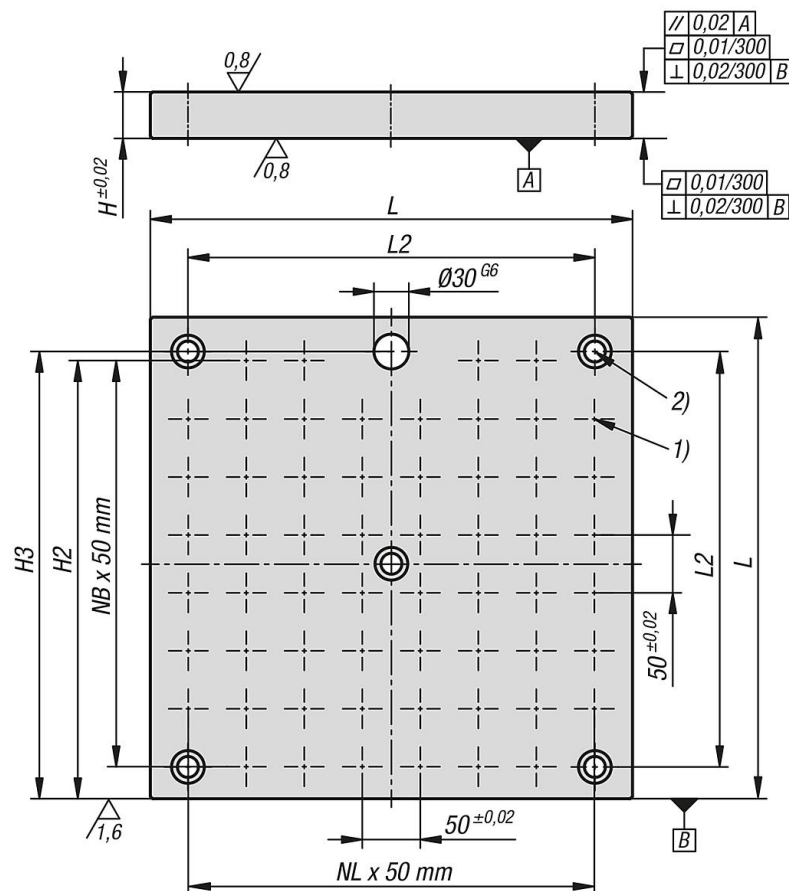

Interchangeable subplates, grey cast iron with grid holes

Overview of items

Interchangeable subplates, grey cast iron, with grid holes

Order No.	L	H	D	D1	H2	H3	L2	N1=No. of grid holes	NL=No. lengthwise	NB= No. across	No. of fastening holes
K0801.2124040	400	40	12	M12	370	370	350	58	7	7	5
K0801.2125050	500	40	12	M12	470	470	450	94	9	9	7
K0801.2126363	630	40	12	M12	585	600	580	138	11	11	7
K0801.2128080	800	50	12	M12	770	770	750	250	15	15	7
K0801.2164040	400	40	16	M16	370	370	350	58	7	7	5
K0801.2165050	500	40	16	M16	470	470	450	90	9	9	7
K0801.2166363	630	40	16	M16	585	600	580	138	11	11	7
K0801.2168080	800	50	16	M16	770	770	750	246	15	15	7