

Baseplates, grey cast iron, round, with grid holes

Item description/product images



Description

Material:
GJL 300.

Version:
Support and mounting surfaces ground

Note:

Grid spacing $50 \pm 0,02$ mm.

Round baseplates with grid holes are used for setting up modular fixtures. These baseplates are positioned and mounted directly on machine tables.

The aligning holes are used to align the baseplate on the machine table.

Please order locating pins to locate the baseplates separately.

Please order protection plugs to plug unused grid holes separately.

Ring bolts for hoisting are supplied.

Other dimensions available on request.

On request:

other dimensions.

Drawing reference:

1) grid hole

2) hole for DIN 912 cap screw (D4)

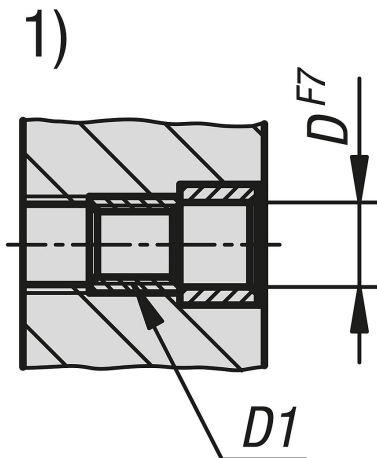

Drawings

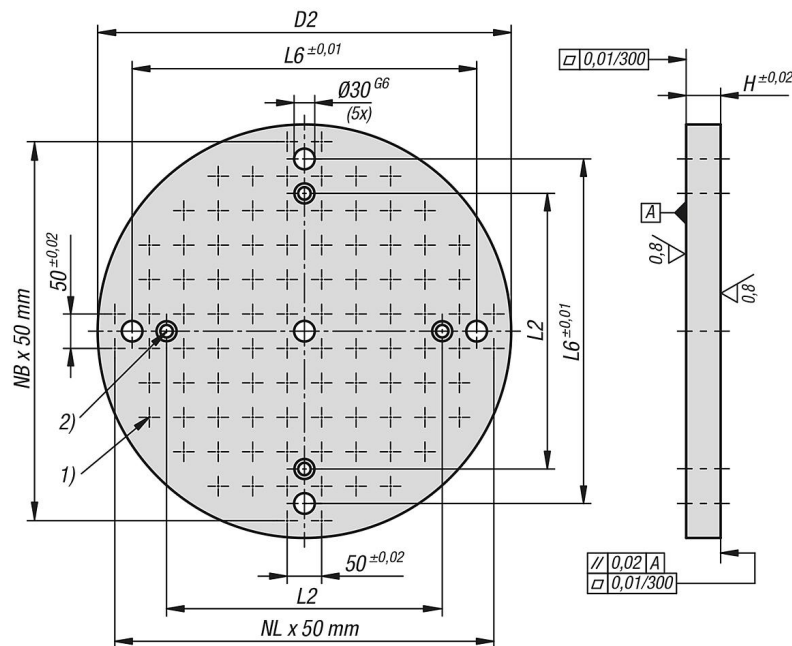

Overview of items

Baseplates, grey cast iron, round, with grid holes

Baseplates, grey cast iron, round, with grid holes

Overview of items

Order No.	D2	H	D	D1	D4	L2	L6	N1=No. of grid holes	NL=No. lengthwise	NB= No. across
K1532.21230050	300	50	12	M12	M12	150	220	24	5	5
K1532.21240050	400	50	12	M12	M12	250	320	44	7	7
K1532.21250050	500	50	12	M12	M16	300	400	68	9	9
K1532.21260050	600	50	12	M12	M16	400	500	96	11	11
K1532.21650050	500	50	16	M16	M16	300	400	68	9	9
K1532.21660050	600	50	16	M16	M16	400	500	96	11	11