

Disc handwheels, aluminium with fold-down cylindrical grip, Form B with reamed hole, keyway and transverse bore

Item description/product images



Description

Material:

Handwheel aluminium.
Cylinder grip and hub cover black thermoplastic.
Cylinder grip pin black oxidised steel.
ISO 4027 grub screw, steel grade 45 H, black.

Version:

Black or silver powder-coated.

Note:

Wheel rim radial and axial run-out ≤ 0.4 mm.

Assembly:

The hub cover is supplied unassembled.
The handwheels can be secured to a shaft using a transverse pin or by parallel key connection together with a DIN 6912 cap screw and a handwheel washer K0173.
By the versions with transverse bore, fixation is carried out using an ISO 4027 grub screw.

Supplied with:

Aluminium handwheel.
Hub cover.
Fold-down cylinder grip.
ISO 4027 grub screw (type with transverse bore).

Accessory:

K0173 Handwheel washers.
K1160 Socket head screws with low head DIN 6912.

Drawing reference:

1) Position of the transverse bore to the keyway is offset by 90° .

Disc handwheels, aluminium with fold-down cylindrical grip, Form B with reamed hole, keyway and transverse bore

Item description/product images



Drawings

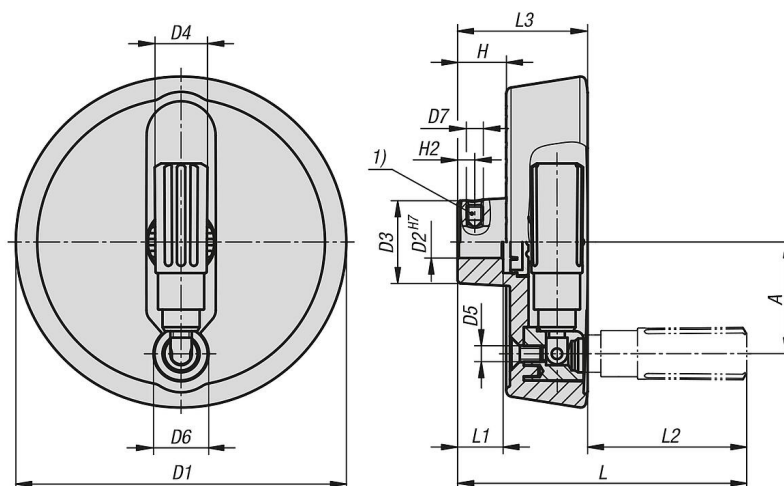

Disc handwheels, aluminium with fold-down cylindrical grip, Form B with reamed hole, keyway and transverse bore

Drawings

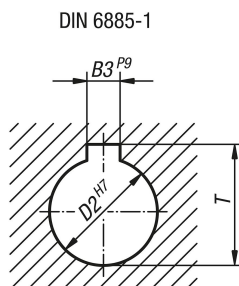

Overview of items

Order No.	Main colour	Form	Form definition	A	B3	D1	D2	D3	D4	D5	D6	D7	H	H2	L	L1	L2	L3	T
K1522.100101036	black	B	reamed hole with slot, with transverse bore	33	3	100	10	28	16	M5	16	M6	17,4	5,5	92,5	17	47,5	45	11,4
K1522.100121046	black	B	reamed hole with slot, with transverse bore	33	4	100	12	28	16	M5	16	M6	17,4	6,5	92,5	17	47,5	45	13,8
K1522.125121046	black	B	reamed hole with slot, with transverse bore	42	4	125	12	31	19,9	M6	20	M6	18,3	6,5	105,5	18	56,5	49	13,8
K1522.125141056	black	B	reamed hole with slot, with transverse bore	42	5	125	14	31	19,9	M6	20	M6	18,3	6,5	105,5	18	56,5	49	16,3
K1522.100102036	silver	B	reamed hole with slot, with transverse bore	33	3	100	10	28	16	M5	16	M6	17,4	5,5	92,5	17	47,5	45	11,4
K1522.100122046	silver	B	reamed hole with slot, with transverse bore	33	4	100	12	28	16	M5	16	M6	17,4	6,5	92,5	17	47,5	45	13,8
K1522.125122046	silver	B	reamed hole with slot, with transverse bore	42	4	125	12	31	19,9	M6	20	M6	18,3	6,5	105,5	18	56,5	49	13,8
K1522.125142056	silver	B	reamed hole with slot, with transverse bore	42	5	125	14	31	19,9	M6	20	M6	18,3	6,5	105,5	18	56,5	49	16,3