

## 2-spoke handwheels, aluminium, without grip, Form E with reamed hole

### Item description/product images



### Description

#### Material:

Handwheel aluminium.

Hub cover black thermoplastic.

ISO 4027 grub screw, steel grade 45 H, black.

#### Version:

Black or silver powder-coated.

#### Note:

Wheel rim radial and axial run-out  $\leq 0.4$  mm.

#### Assembly:

The hub cover is supplied unassembled.

The handwheels can be secured to a shaft using a transverse pin or by parallel key connection together with a DIN 6912 cap screw and a handwheel washer K0173.

By the versions with transverse bore, fixation is carried out using an ISO 4027 grub screw.

#### Supplied with:

Aluminium handwheel.

Hub cover.

ISO 4027 grub screw (type with transverse bore).

#### Accessory:

K0173 Handwheel washers.

K1160 Socket head screws with low head DIN 6912.

Item description/product images

---

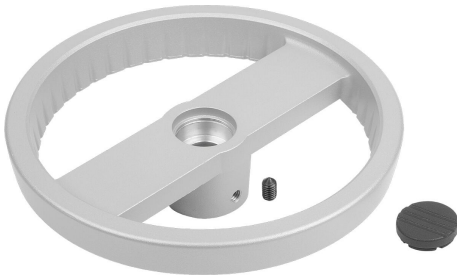
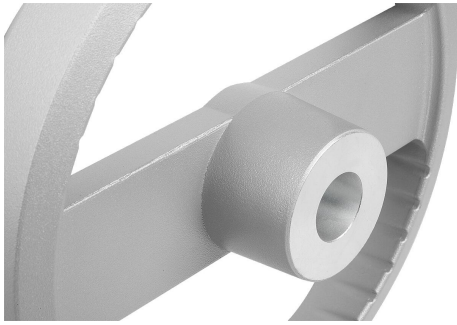

Drawings

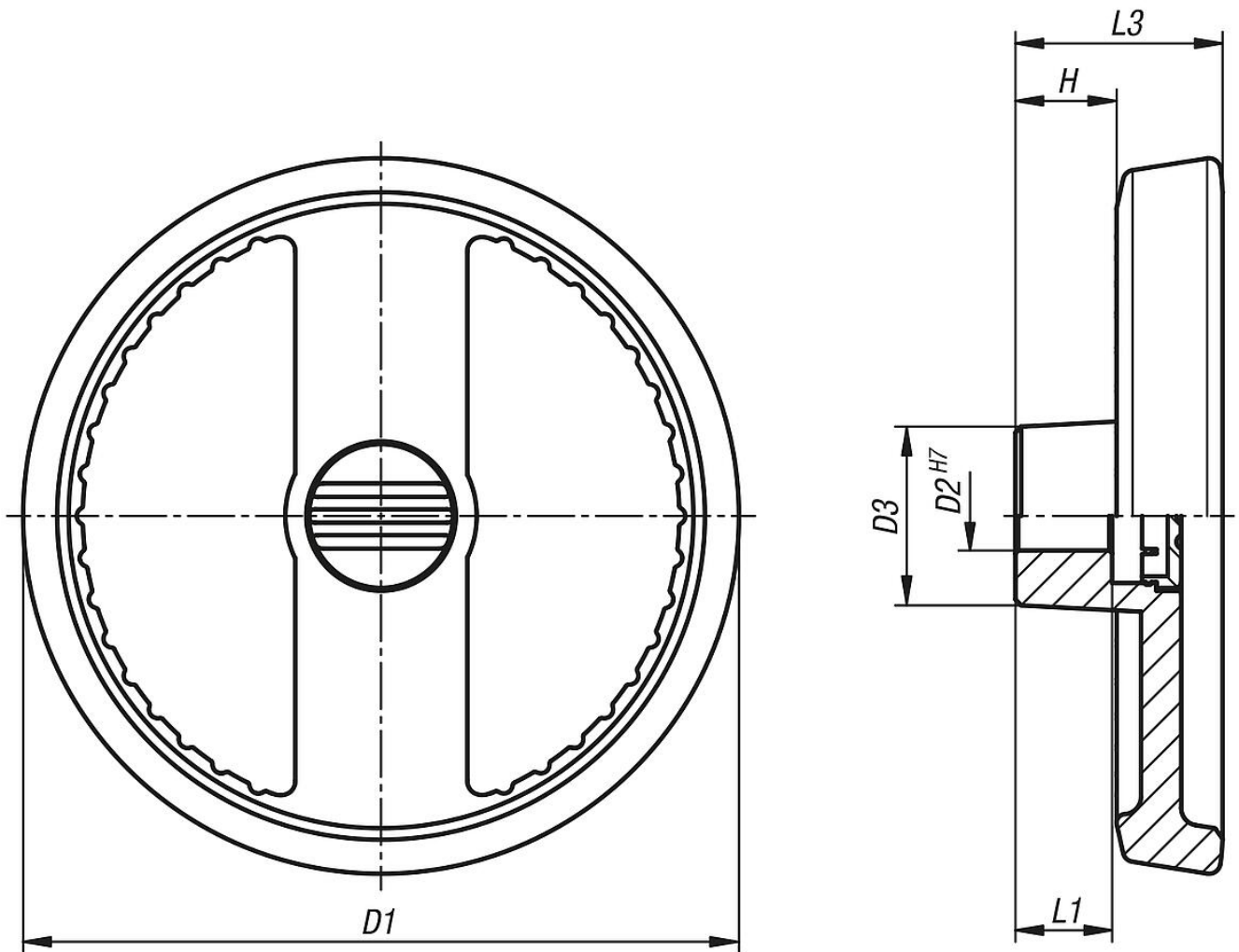

Overview of items

Order No.	Main colour	Form	Form definition	D1	D2	D3	L1	L3	H
K1523.125121	black	E	with reamed hole	125	12	31	18	36	17,6
K1523.125141	black	E	with reamed hole	125	14	31	18	36	17,6
K1523.160141	black	E	with reamed hole	160	14	36	20	40	19,4
K1523.160161	black	E	with reamed hole	160	16	36	20	40	19,4
K1523.125122	silver	E	with reamed hole	125	12	31	18	36	17,6
K1523.125142	silver	E	with reamed hole	125	14	31	18	36	17,6
K1523.160142	silver	E	with reamed hole	160	14	36	20	40	19,4
K1523.160162	silver	E	with reamed hole	160	16	36	20	40	19,4